OPTIONAL SERVICE BULLETIN NO. 40NG-032 REV. 2

SUPERSEDES OSB 40NG-032 REV. 1

I TECHNICAL DETAILS

I.1 Category

Optional.

I.2 Airplanes Affected

Type: DA 40, DA 40 D, DA 40 F, DA 40 NG

Serial numbers: 40.005 through 40.009
40.011 and subsequent
D4.001 and subsequent
40.DS001 and subsequent
40.F001 and subsequent
40.FC001 and subsequent
40.N001 and subsequent
40.NC001 and subsequent
40.NS001 and subsequent

I.3 Date of Effectivity

25-Feb-2019

I.4 Time of Compliance

At owner's discretion.

I.5 Subject

Installation provisions for a safety mesh to protect the fuel tank vents.

I.6 Reason

Installation provisions for a safety mesh to prevent small insects from entering the fuel tank vent holes while the airplane is parked on the ground.

I.7 Concurrent Documents

None.

I.8 Approval

The technical information or instructions contained in this document relate to the Design Change Advisories No. OÄM 40-1016, which is approved as part of the type design, and OÄM 40-385, which has been approved under the authority of EASA Design Organization Approval ref. EASA.21J.052.

I.9 Accomplishment/Instructions

Drill a hole in the fuel vent cover system; install a camloc and retaining nut i.a.w. drawing:

DRAWING	APPLICABILITY	
	MODEL	S/N
D4D-5741-00-00X03 (LH)	DA 40 D	D4.001 and subsequent
D4D-5742-00-00X03 (RH)	DA 40 NG	40.DS001 and subsequent
DA4-5741-25-00X01	DA 40	40.N001 and subsequent
DA4-5741-25-00X02	DA 40	40.005 through 40.084
	DA 40 F	40.085 through 40.199 40.335 through 40.1279
DA4-5741-25-00X03	DA 40	40.FC001 through 40.FC029
	DA 40 F	40.1280 and subsequent 40.F001 and subsequent 40.FC030 and subsequent

I.10 Mass (Weight) and CG

Negligible.

II PLANNING INFORMATION

II.1 Material and Availability

QTY	PART NUMBER	DESCRIPTION	APPLICABILITY	
			MODEL	S/N
2	D4D-5741-11-00-SP	Fuel vent safety cover	DA 40 D	D4.001 and subsequent 40.DS001 and subsequent
	DA4-5741-25-00-SP1		DA 40 NG	40.N001 and subsequent
	DA4-5741-25-00-SP2		DA 40	40.005 through 40.084
			DA 40 F	40.085 and subsequent 40.F001 and subsequent 40.FC001 and subsequent
2	99N10-01A1	Retaining nut	All	
2	99E10-01	Camloc receptacle	All	

II.2 Special Tools

None.

II.3 Labour Effort

Approx. 2 hours.

II.4 Credit

None.

II.5 Reference Documents

DA 40 NG Airplane Maintenance Manual, Doc. No. 6.02.15, latest effective issue.

III REMARKS

1. All work must be done by a certified aircraft service station, or a certified aircraft maintenance mechanic.
2. All work, in particular, which is not especially described in this service bulletin, must be done in accordance with the referenced maintenance manual.
3. Completion of all work must be recorded in the logbook.
4. In case of doubt, contact Diamond Aircraft Industries Canada.



**EXECUTION REPORT TO
SERVICE BULLETIN
MSB 40NG-032 REV. 2**

AIRPLANE INFORMATION

Airplane Serial Number _____

Airplane Registration _____

Airplane Operator _____

Hours of Operation of Airplane _____

No. of Landings _____

Hours of Operation of Engine _____

Typical Operation of Airplane _____
(private, club, training, other)

Date, Name, Signature

Please e-mail the completed form to Techpubs@diamondair.com.

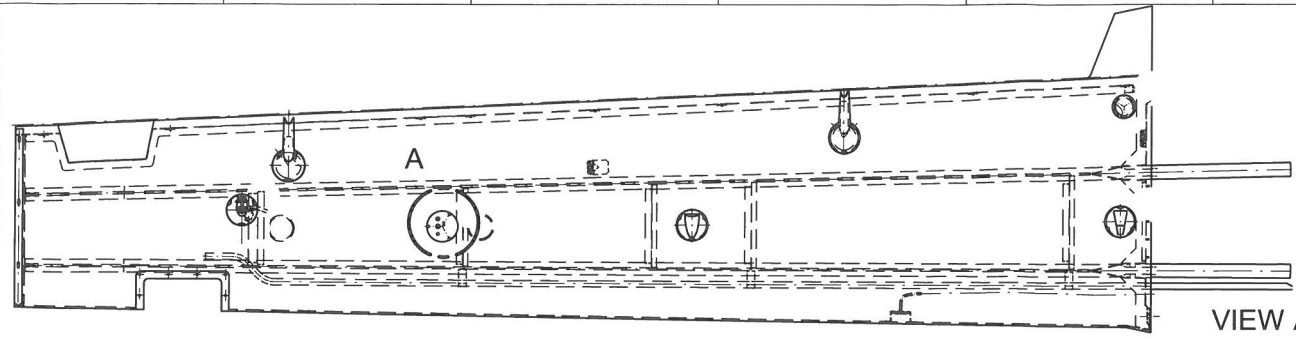

VIEW A

SECTION B-B

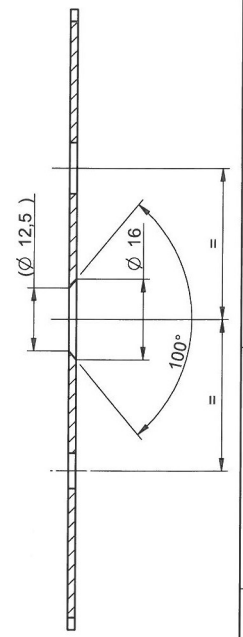
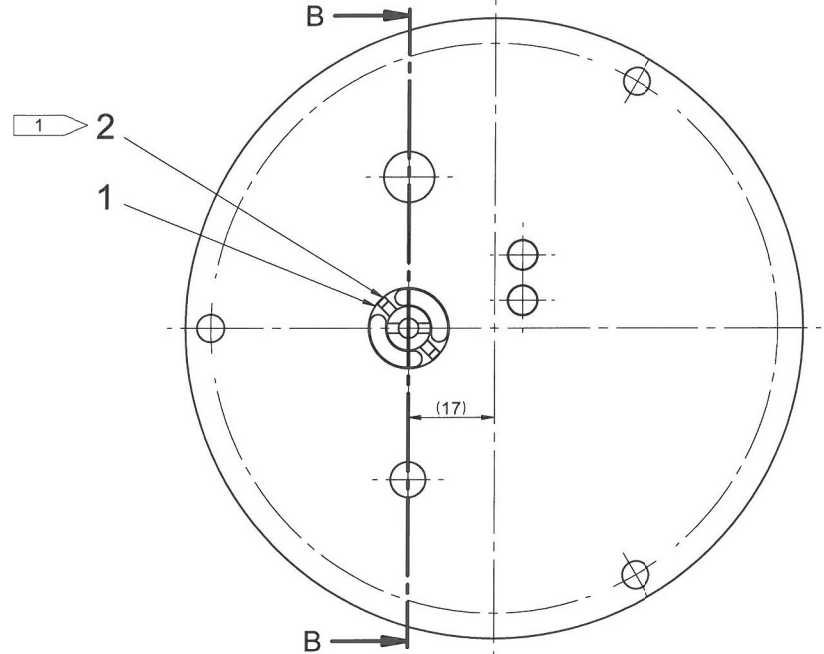

ITEM	QTY	PART NUMBER	DESCRIPTION	MATERIAL TYPE	H.T.	MATERIAL SIZE	SPECIFICATION	REMARK
2	2	99N10-01A1	RETAINING NUT					
1	2	99E10-01	CAMLOC RECEPTACLE					CAMLOC

GENERAL NOTES
1. PERFORM ON LH AND RH WING.

FLAG NOTES
1. SECURE USING THICKENED RESIN

DIMENSIONS METRIC	
FIRST ANGLE PROJECTION	FORMAT A3
UNLESS OTHERWISE SPECIFIED DIMENSIONS ARE IN MM	
DIMENSION TOLERANCES	
2 DECIMAL	+0,25
1 DECIMAL	+0,5
DECIMAL	±1
ANGLE	±1°
RAD	+0,5
FINISH	IN MICRO-METER

OSB D4-092
OSB 40NG-032

PROJECT		
TITLE		
PROVISIONS FOR FUEL VENT COVER INSTALLATION LH/RH		
DWG. ORIG.	DWG. NO.	REV
DAIA	D4D-5741-00-00X03	-
	D4D-5742-00-00X03	
CODE 710197	SCALE 1:20, 1:1	SH 01 OF 01

ALL RIGHTS RESERVED FOR THIS DOCUMENT WHICH MAY NOT BE REPRODUCED OR DISCLOSED TO THIRD PARTIES WITHOUT THE PRIOR WRITTEN CONSENT OF DIAMOND AIRCRAFT INDUSTRIES